

## Using PSCAD for Studying Bus Transfer Transients in a Nuclear Power Plant

PSCAD/EMTDC was used by Washington Group International for performing a fast bus transfer study on Entergy Corp.'s IPEC Energy Center Indian Point 2 (IP2). The simulation model consisted of about 50 induction motors both at the 6.9kV and 480V voltage levels with dynamic load torques, nine (9) transformers, tap changers, a bus transfer scheme, bus faults, load sequencing, more than 70 breakers, cables, and transmission lines. The top level diagram of the PSCAD case constructed from

connected page components is shown below in Figure 1.

This study analyzed the IP2 electrical distribution system for a Safety Injection (SI) load sequencing event, including the motor starting transients, and fast bus transfer of the Unit Auxiliary Transformer (UAT) loads to the Station Auxiliary Transformer (SAT) with a 6 cycle dead-bus time. A Safety Injection (SI) is the process that provides borated water to cool the reactor core in the event of a loss of coolant accident (LOCA).

The objective of this analysis was to determine the terminal voltage profiles of all the safety related motors for a given sequence of motor starting and operation during the first 58 seconds after the SI event to make sure that the motors can operate within their specified range. The study also addressed the impact of voltage variation at the 138kV Buchanan substation that feeds the SAT, initial tap positions and fault conditions.

The case was set up to study 12 cases (scenarios) with 8 parameters being set for each case. It was very

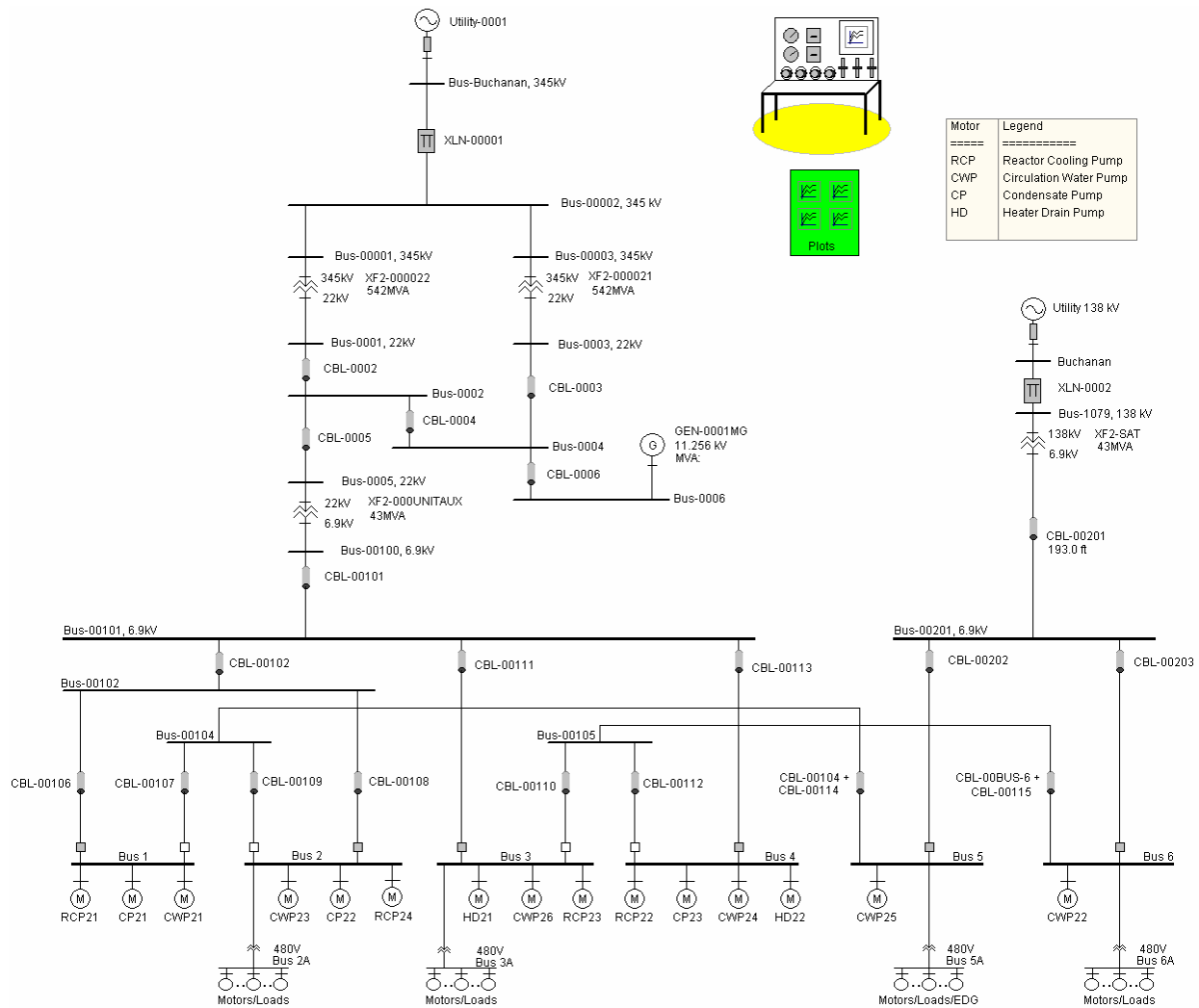

Figure 1: Indian Point 2 Nuclear Power Plant PSCAD Circuit

important to organize the case in a systematic way to minimize the potential for error in data entry and version control. The case was arranged in three hierarchical levels: top level, 6.9 kV and up, and 480 Volts. All the case parameters were set in one location using table components which are selected by a selector switch input. See PSCAD programming blocks below in Figures 2 and 3.

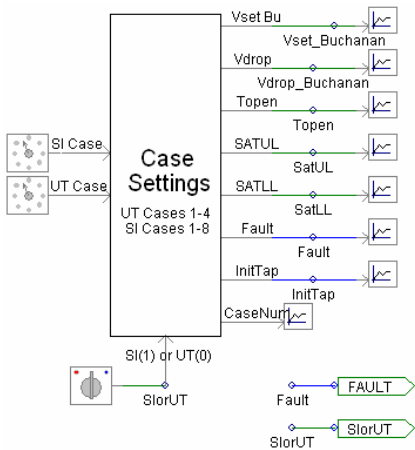

Figure 2: Case Setting Control Interface

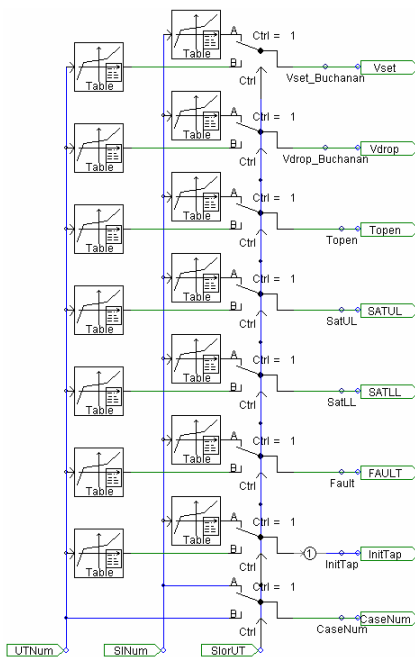

Figure 3: Case Settings Definition

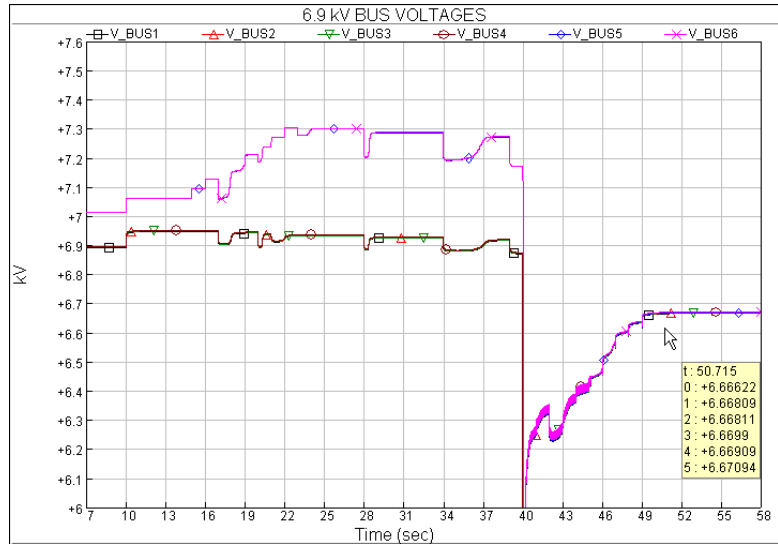

Figure 4: 6.9 kV Bus Voltage During SI and Fast Bus Transfer

The case parameters were passed to other modules through import/export connections. Thus, any case could be simulated by simply changing the case selector switch.

Since this was a nuclear safety related study, only nuclear certified software can be used. PSCAD was verified and validated according to Software Quality Assurance (SQA) regulatory guides and Washington Group International SQA procedures prior to the study. The results of PSCAD were verified and validated against other nuclear certified analysis tools such as power flow and other transient analysis programs. Where appropriate, verification was performed using hand calculations and proofs. Samples of

output are shown in Figure 4 for the 6.9kV bus, and Figure 5 for the 480 volt bus. PSCAD results matched within 0.5% taking into consideration differences in the methods of analysis and modeling details.

The study determined successful bus transfer capability of IP2 in all cases. As a result of the successful conclusion of this study, PSCAD/EMTDC is now in use by Washington Group for other nuclear safety related studies.

Om Nayak (Nayak Corporation) and Ravi Yedithi (Washington Group International)

*Originally published in the Manitoba HVDC Research Centre Journal- Winter 04'*

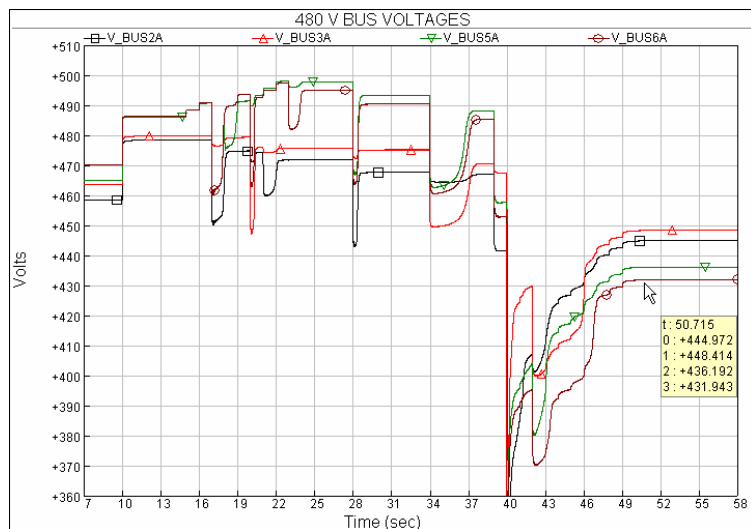

Figure 5: 480 V Bus Voltage During SI and Fast Bus Transfer